

DSP Lab Manual

Sophocles J. Orfanidis

Spring 2014

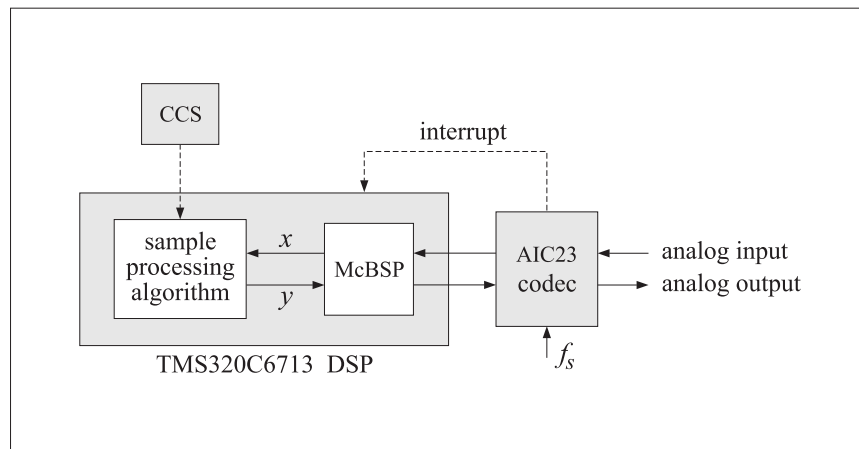

Lab Schedule – Spring 2014

Week	Group	Labs
2/03 2/10	A B	Lab1 – CCS introduction, aliasing, quantization, data transfers, guitar distortion
2/17 2/24	A B	Lab2 – CCS, sinusoids, wavetables, AM/FM, ring modulators, tremolo
3/03 3/10	A B	Lab3 – Delays, circular buffers, FIR filters, voice scrambler
3/17		
3/24	A & B	Lab4 – Sampling, aliasing, FIR filtering (software lab)
4/07 4/14	A B	Lab5 – Digital audio effects, reverb, multi-delay, guitar strings, flangers, vibrato
4/21	A & B	Lab6 – IIR filtering experiments (software lab)

Notes

1. Labs meet in room ELE-209.
2. The lab sessions have a duration of two periods. Attendance in all labs is required (it is not possible to get an “A” in the lab course if one of these sessions is missed.) Due to the limited number of workstations, missed hardware labs cannot be made up.
3. Each lab section has been split into two groups, A & B, that meet on alternate weeks as shown on the above schedule. The groups are as follows, divided according to student last names (please note that these may change until registration is closed):

Section	Group A	Group B
Section-1, Th 10:20 AM - 1:20 PM	Agarwal - Loh	MacPhee - Zieder
Section-2, W 3:20 PM - 6:20 PM	Ali - Patel	Peirce - Young
Section-3, F 8:40 AM - 11:40 AM	Beard - Wei	
TA	S. Sun / T. Wu	T. Wu / S. Sun

Contents

0	Introduction	1
0.1	Lab Guidelines	1
0.2	Running C Programs	1
0.3	Using MATLAB	3
0.4	References	6
1	TMS320C6713 DSK and Code Composer Studio	7
1.1	Introduction	7
1.2	Lab Tasks	9
1.3	Template Program	9
1.4	Aliasing	12
1.5	Quantization	14
1.6	Data Transfers from/to Codec	14
1.7	Guitar Distortion Effects	16
1.8	References	18
2	Wavetable Generators, AM/FM Modulation	20
2.1	Lab Tasks	20
2.2	Wavetable Generators	20
2.3	Sinusoidal Wavetable	21
2.4	AM Modulation	23
2.5	FM Modulation	24
2.6	Ring Modulators and Tremolo	26
2.7	Scrambler as Ring Modulator	27
2.8	References	28
3	Delays and FIR Filtering	29
3.1	Introduction	29
3.2	Delays Using Linear and Circular Buffers	29
3.3	FIR Comb Filters Using Circular Buffers	34
3.4	FIR Filters with Linear and Circular Buffers	36
3.5	Voice Scrambler	43
3.6	References	46
4	Sampling, Aliasing, FIR Filtering	47
4.1	Sampling and Aliasing – Sinusoids	47
4.2	Sampling and Aliasing – Square Wave	47
4.3	FIR Filtering	50
4.4	Filtering of Noisy Signals	51
5	Digital Audio Effects	56
5.1	Plain Reverb	56
5.2	Allpass Reverb	58
5.3	Lowpass Reverb	60
5.4	Schroeder’s Reverb Algorithm	61
5.5	Stereo Reverb	63
5.6	Reverberating Delay	65
5.7	Multi-Delay Effects	66
5.8	Multitap Delay Effects	67
5.9	Karplus-Strong String Algorithm	68
5.10	Flangers and Vibrato	70
5.11	References	71

<i>CONTENTS</i>	4
6 IIR Filtering Experiments	73
6.1 Transposed Realization	73
6.2 Feedback System	75
References	78